

INSTALLATION & OPERATION MANUAL



901777

901605 = mt.2

901767.02

905774-03

901691.01 3 mt. 6/6

901226

901805

IST030

x2

x2

x5

x5

901649

901736

700037

PACKING

AxBxC	x	x
netto	Kg.	
lordo	Kg.	
	m ³	

CDS-JOHN BLUE COMPANY

FM - 10

MODEL FM-10

USE OF FOAM MARKER

The foam marker is used to mark the working area with balls of foam. It eliminates the risk of improper overlapping and space gaps during the spraying and/or spreading process. The foam marker was designed to fit very small sprayers (ATV sprayer).

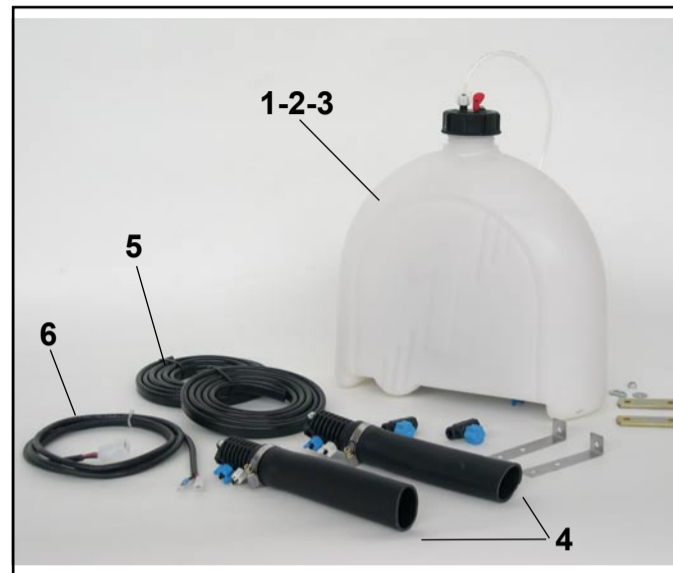

COMPONENTS

The foam marker has the following major components:

1. 1 gallon tank
2. 12 Vdc air compressor

3. Right and left (on-off-on) switch box
4. Foam nozzle assembly
5. Power supply & compressor cable
6. Air-liquid tubing

NOTE: PLEASE REFER TO THE PARTS BREAK DOWN FOR THE COMPLETE COMPONENTS LIST

www.cds-johnblue.com

1-800-253-2583

INSTALLATION PROCEDURES

IMPORTANT: Read all instructions before installing and operating the foam marker.

DIMENSION & WEIGHT

When empty, the weight of the foam marker is 12 lbs.

INSTALLATION OF SWITCH BOX AND POWER SUPPLY

- Determine the best location for the selector switch box in the tractor cab.

OVERALL DIMENSIONS

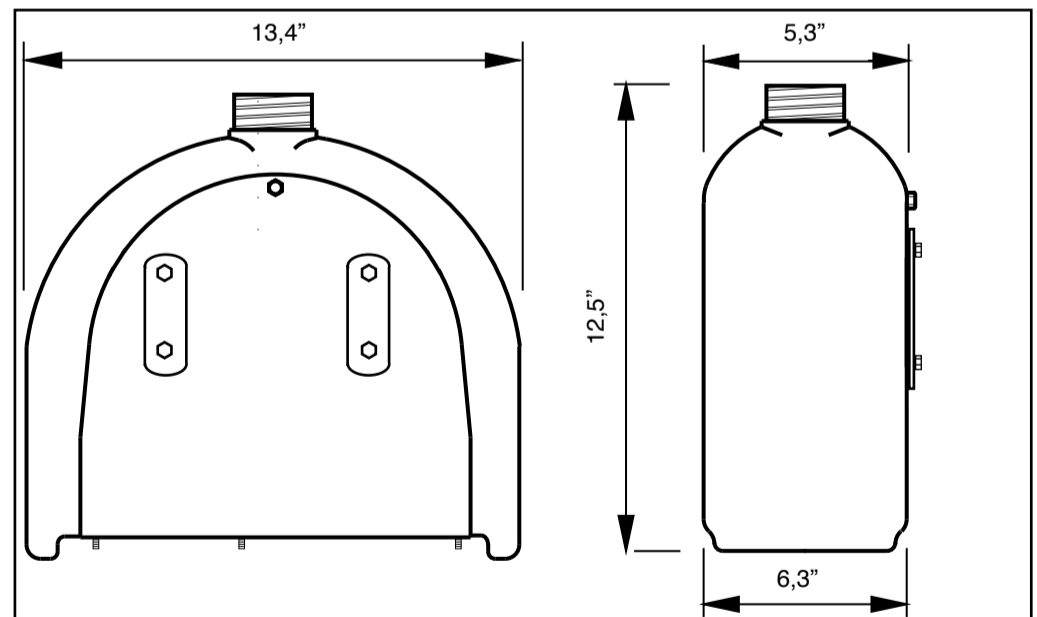

GENERAL INSTALLATION INSTRUCTIONS

The Foam Marker can be easily installed on sprayers, tractors or ATVs. As a general rule it is important to choose a location for the compressor that shields it from exposure to chemicals during spraying operations.

The two foam drop nozzles must be fixed at the ends of the boom so that foam can fall at the edge of the end spray nozzle signaling the sprayed area.

Hoses for the air-liquid circuit must be

- Determine the best routing for the power cable. Make sure it is away from operator's movement area, away from moving parts and away from sharp objects.

- Using 3 bolts 1/4" (not included) and the provided slots, mount the switch box at the desired location.

- Using the power supply cable, connect the switch box to the battery.

- Using the compressor cable, connect the switch box to the tank.

250009

200037

100134

901024

100069

100070

100133

100023

100127

901227

200114

200113

200037

210531

200037

200044

200043

200037

200044

200043

901016

901503

235008

100023

100127

210531

200037

100054

299047

235009

200039

250059

100118

200039

901209

901225

901777

CDS-JOHN BLUE COMPANY

FM - 10

901217

901648

901736

901226

100126

901204

100125

901767.02

901691.01 = 3 mt. 6/6

901691.01 = 3 mt. 6/6

905774-03=mt.3

INSTALLATION OF TANK

- Mount the tank using the 4 provided bolts. See figure for detailed dimensions.
- Use the provided brackets to tighten the tank.
- Use the provided locknut to tightent the brackets.

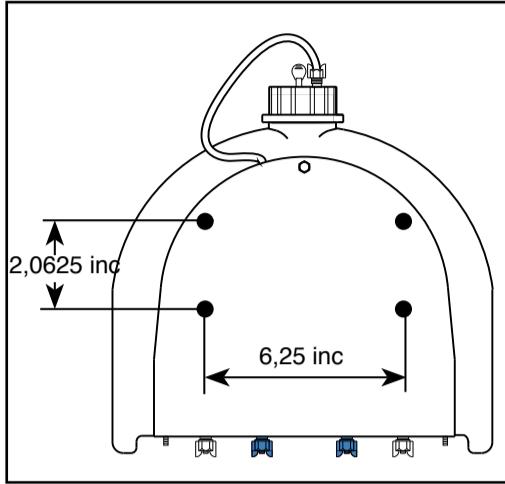

INSTALLATION OF FOAM NOZZLE

- With the provided holes, mount the L-shape brackets on each side of the boom (bolts are not included)
- Remove the bolt and nut from the foam nozzle.
- Slide the foam nozzle and L-shape bracket until the two holes are aligned.
- Insert back the bolt and nut. Tighten the screw using a screwdriver.

AIR CONNECTION OF CAP

- Air connection to the cap of the tank is factory mounted. However if it is not, connect the clear tube (air outlet) coming from the compressor to the white wing nut of the cap.

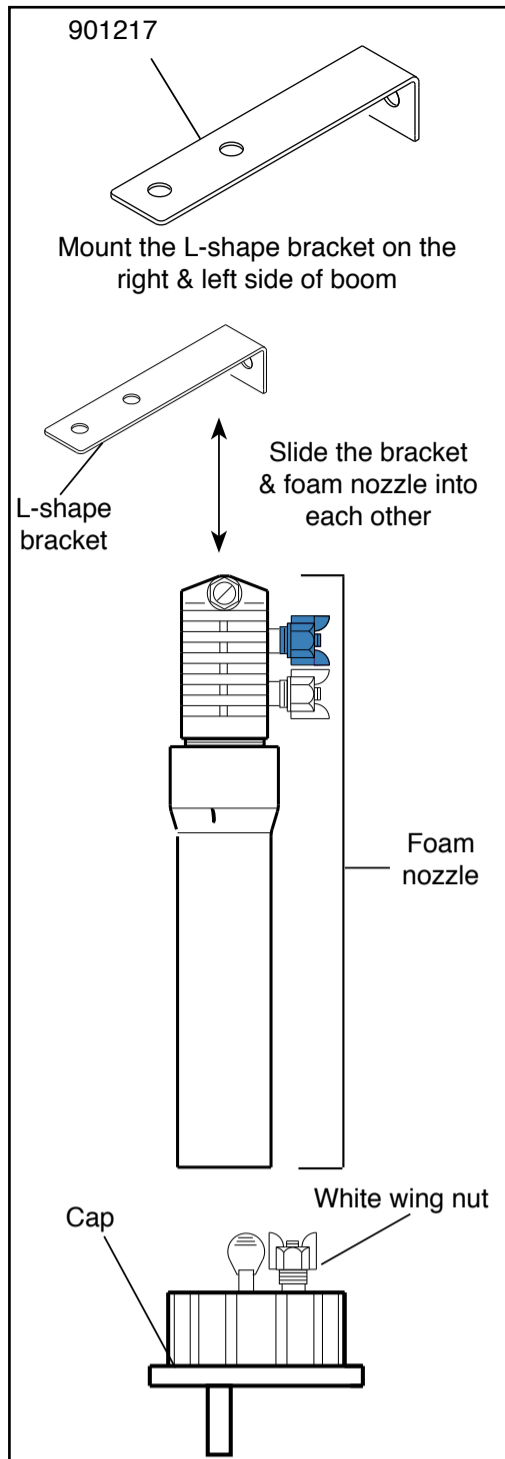

3

OPERATION

SWITCH BOX

⚠ The switch box is used to start the compressor and to select the side the foam will be made. To operate simply select "ON" left or "ON" right to direct the foam to the left or right side of the boom. Selecting "OFF" will not drop foam at all.

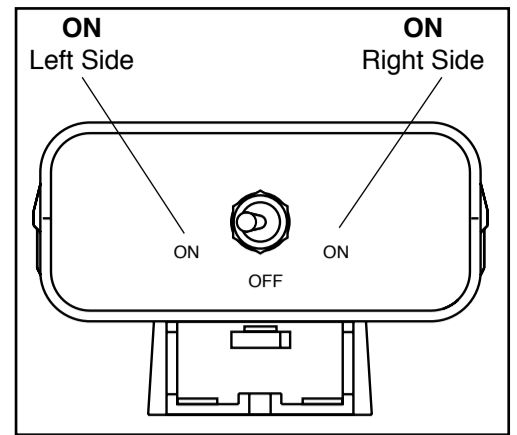

MIXING SOAP IN TANK & CONTROLLING THE FLOW

⚠ CAUTION: CONTENTS IN TANK MAY BE UNDER PRESSURE. WHEN REMOVING CAP FROM TANK, UNSCREW CAP SLOWLY TO RELIEVE PRESSURE OR USE THE INSTALLED RELEASE VALVE.

Remove cap from tank. Fill the tank with the desired amount of water first, and then add soap. To avoid making unnecessary foam in the tank, always add water first, then soap. Replace cap on the tank and tighten hand tight. Temperature, sunlight, relative humidity, hardness of water, soap concentration and wind condition are some of the variables which affect the foam ball life span.

When using Salvarani foam agent, 1 to 3 ounces of soap agent should be used for 1 gallon of water. **NOT ALL SOAP AGENTS ARE EQUAL !!!**

The foam nozzle, has flow regulator to control the output of the foam liquid. By turning the knob clockwise, the foam ball output will be less frequent. By turning the knob counter clockwise, the foam ball output will be more frequent.

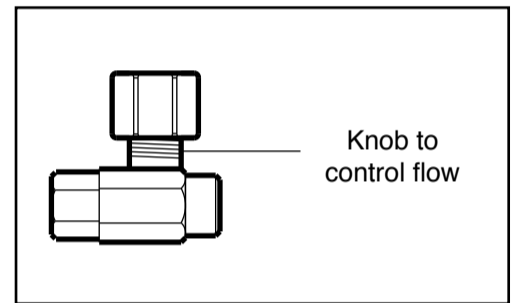
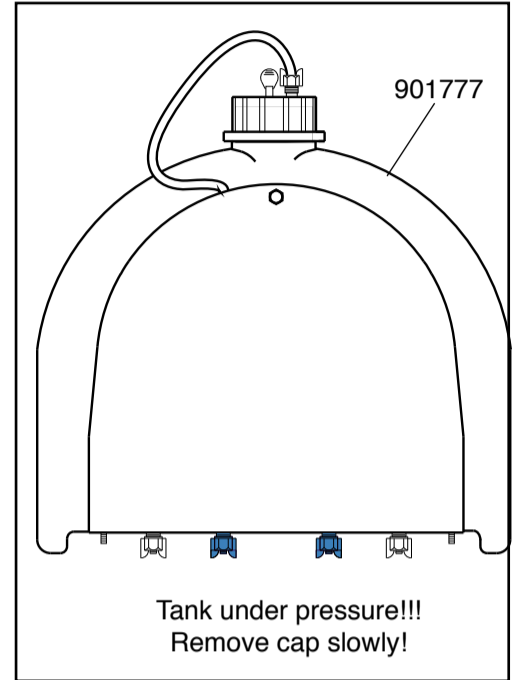

5

INSTALLATION OF FLOW REGULATOR

- Insert the blue tube in the flow regulator. It is important to insert the tube from the non-threaded side.
- Remove the blue wing nut on the foam nozzle.
- Slide the blue tube from the flow regulator around the fitting. **MAKE SURE TO SLIDE IT COMPLETELY**
- Turn the flow regulator clock wise.

INSTALLATION OF AIR-LIQUID TUBING

- After installing the flow regulator, insert the other side of the blue tube in the fitting under the tank (the fitting with the blue label).
- Using the blue wing nut, tighten the blue tube under the tank. **ALWAYS MAKE SURE THE TUBE GOES ALL THE WAY IN THE FITTING.**
- With the white or clear tube, insert one end to the foam nozzle fitting and the other end under the tank (the fitting with the white labe l).
- Using the white wing nut, tighten the white tube under the tank and on the foam nozzle
- Repeat the operation for the other side of the boom

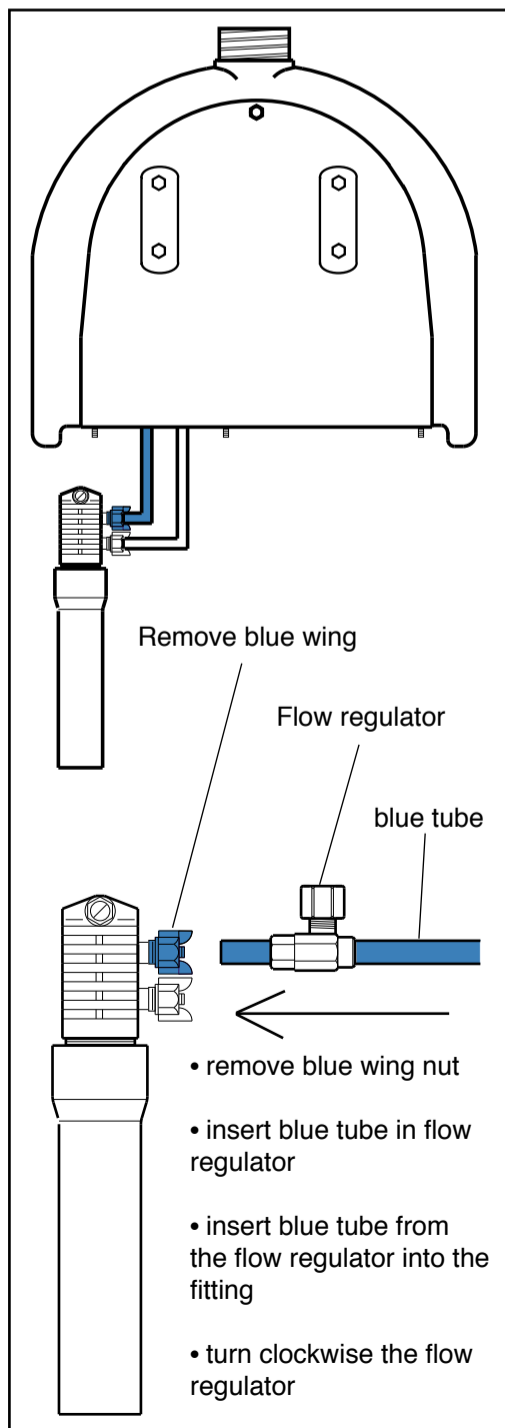
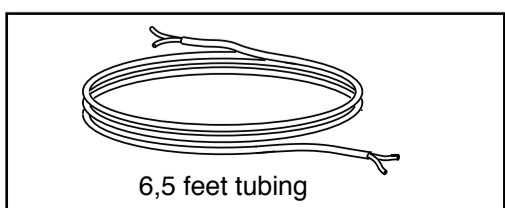

4

TROUBLESHOOTING

The following table summarizes different problem conditions.

CONDITION	POSSIBLE CAUSES	SOLUTIONS
1. Compressor will not turn on	A. Corroded connections B. Disconnected C. Blown fuse	A. Inspect and clean B. Check wiring C. Replace fuse
2. Foam does not come out from nozzle	A. No concentrate in tank B. Tank cap loose C. Compressor filter clogged	A. Add concentrate in tank B. Tighten cap C. Clean or replace filter
3. Foam ball does not form completely	A. Soap concentrate to low B. Restrictor not in place C. Water to hard	A. Dump and remix higher B. See foam nozzle assembly in parts break down C. Use water softener with concentrate
4. Foam marker is off but air or liquid are still coming out	A. Valves are dirty B. Valves are broken	A. Blow air in the valves B. Replace broken valves

6