

Select Your Flow Divider

CDS-John Blue Flow Divider

Our Idea of Perfection From One End of Your Field to Another

Liquid fertilizer users demand accurate rates. The patented CDS-John Blue "Exacto-Flow" Flow Divider when used in conjunction with our liquid metering pump is guaranteed to deliver. After extensive research, we know that the FD-1200 and FD-2000 accurately divide liquid products across a wide range of

application rates. We have proven in the field that it is the most accurate distribution of any automatic flow divider system on the market today. The FD-1200 and FD-2000 provide unsurpassed accuracy with application rates as low as 5 GPA and as high as 80 GPA on 30 inch row spacing at 5 MPH.

302 SS balanced spring offers superior performance and corrosion resistance.

Field repairable without removing distribution lines.

Exclusive Viton® lip seal is more stable and has a longer life than conventional diaphragms which may rupture during service.

The upper needle of the piston is 316 SS, which means longer seal life. The special glass-filled Teflon lower needle offers smooth operation with minimum friction.

316 SS sleeve can be easily removed for cleaning in the field. Plus the alignment indicator ensures that the sleeve can be removed, cleaned and replaced exactly in the same position every time.

Viton® o-rings are used for positive sealing for even hard to handle products.

316 SS body is corrosion resistant, durable and built to last a lifetime.

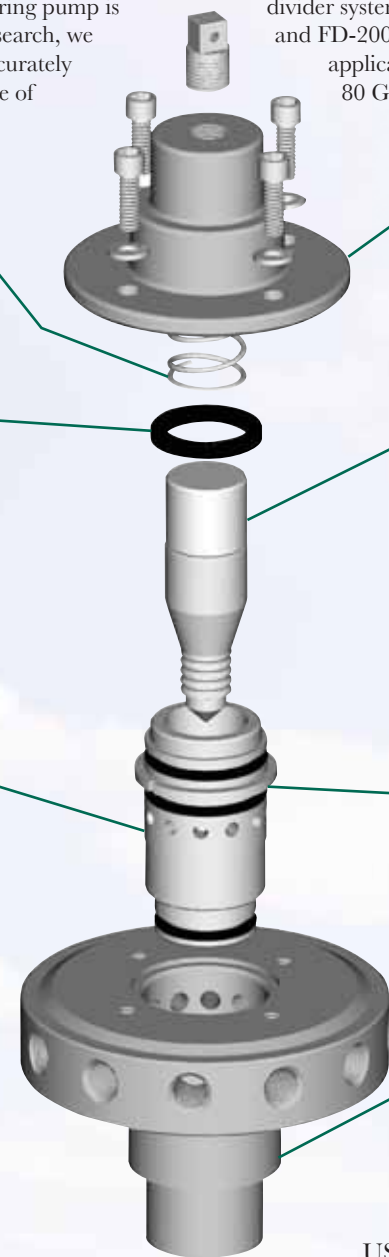

US Pat No 6311716

Flow Divider and Flow Divider Mounts

Part Number	Description	Outlets	Inlet	Outlet	Maximum Flow/Outlet
FD-1200	"Exacto-Flow" Stainless Steel Flow Divider	12	3/4" FPT	1/4" FPT	2.25 GPM
FD-2000	"Exacto-Flow" Stainless Steel Flow Divider	20	1" FPT	1/4" FPT	2.25 GPM
113989	Manifold Mount				
115284-01	Check Valve - PVC, Viton Seal, 316 SS Ball, 1/4" Hose x 1/4" Hose, 1 psi				
115285-01	Check Valve - PVC, Viton Seal, 316 SS Ball, 3/8" Hose x 3/8" Hose, 1 psi				
115286-01	Check Valve - PVC, Viton Seal, 316 SS Ball, 1/2" Hose x 1/2" Hose, 1 psi				

Choosing Your DRV (Ground Drive)

Make Your Fertilizer and Chemical Applications Simple: CDS-John Blue Ground Drives-DRV

The CDS-John Blue Family of **Universal Drive Assemblies-DRV's** make the installation of ground driven pumps on applicators and planters simple. Ground driven pumps have proven they are the most reliable and accurate method of applying liquid fertilizer without exception: **now you can bolt it up quickly and easily!**

The **CDS-John Blue New Ground Drives (DRV's)** make the installation of **the best** easier with standard sprockets and mountings that fit most applicators and planters to provide the application rates you require.

The piston metering pump is the standard for accuracy due to the positive displacement ground driven design, which maintains a constant rate per acre as the ground speed varies. This is accomplished mechanically without any expensive and difficult to service components.



DRV-3000 is ideal for fixed height. Ground Drive with pump mount - fixed height adjustment mechanism (10 positions), less tire and u-bolts.



DRV-3100 Gage Wheel. Fixed height adjustment mechanism (10 positions), less tire and u-bolts.



DRV-3200 Universal Mount that uses the existing shaft from your planter. Pump mount and jackshaft for planter hex shaft drive applications, less u-bolts.



DRV-3300 Complete Ground Drive that automatically adjusts for your terrain. Ground Drive with pump mount - spring loaded adjustment mechanism, less tire and u-bolts.

U-bolts for your bar size (2 u-bolts required per drive):

7" x 7" Bar part number: 115907-01A

4" x 4" Bar part number: 115907-01B

4" x 6" Bar part number: 115907-01C

6" x 6" Bar part number: 115907-01D

Pump Drives

Part Number	Description
107142	Press wheel - without hydraulic cylinder, includes 32T RC 50 sprocket and tire.
114916	Universal planter mount - for metering pumps, 12T RC 40, 32T RC40, 32T RC 40, split socket.
114939	Universal planter mount kit - for squeeze pumps, includes sprocket adaptors and retainers, sprockets, etc.
DRV-3000	Ground Drive with pump mount - fixed height adjustment mechanism (10 positions).
DRV-3100	Gage Wheel only - fixed height adjustment mechanism (10 positions).
DRV-3200	Universal Mount-Pump mount and jackshaft for planter hex shaft drive applications.
DRV-3300	Ground Drive with pump mount-spring loaded adjustment mechanism.

Call Toll Free at 800-253-2583 for free engineering and technical assistance.

Available From:



CDS-John Blue Company, Division of Advanced Systems Technology, Inc.
P.O. Box 1607, Huntsville, AL 35807, Tel: 256-721-9090, FAX: 256-721-9091
Web: www.cds-johnblue.com, E-mail: info@cds-johnblue.com

FPC00109-1-2000

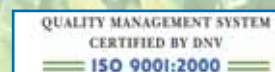

Printed in USA

The Complete Fertilizer Package

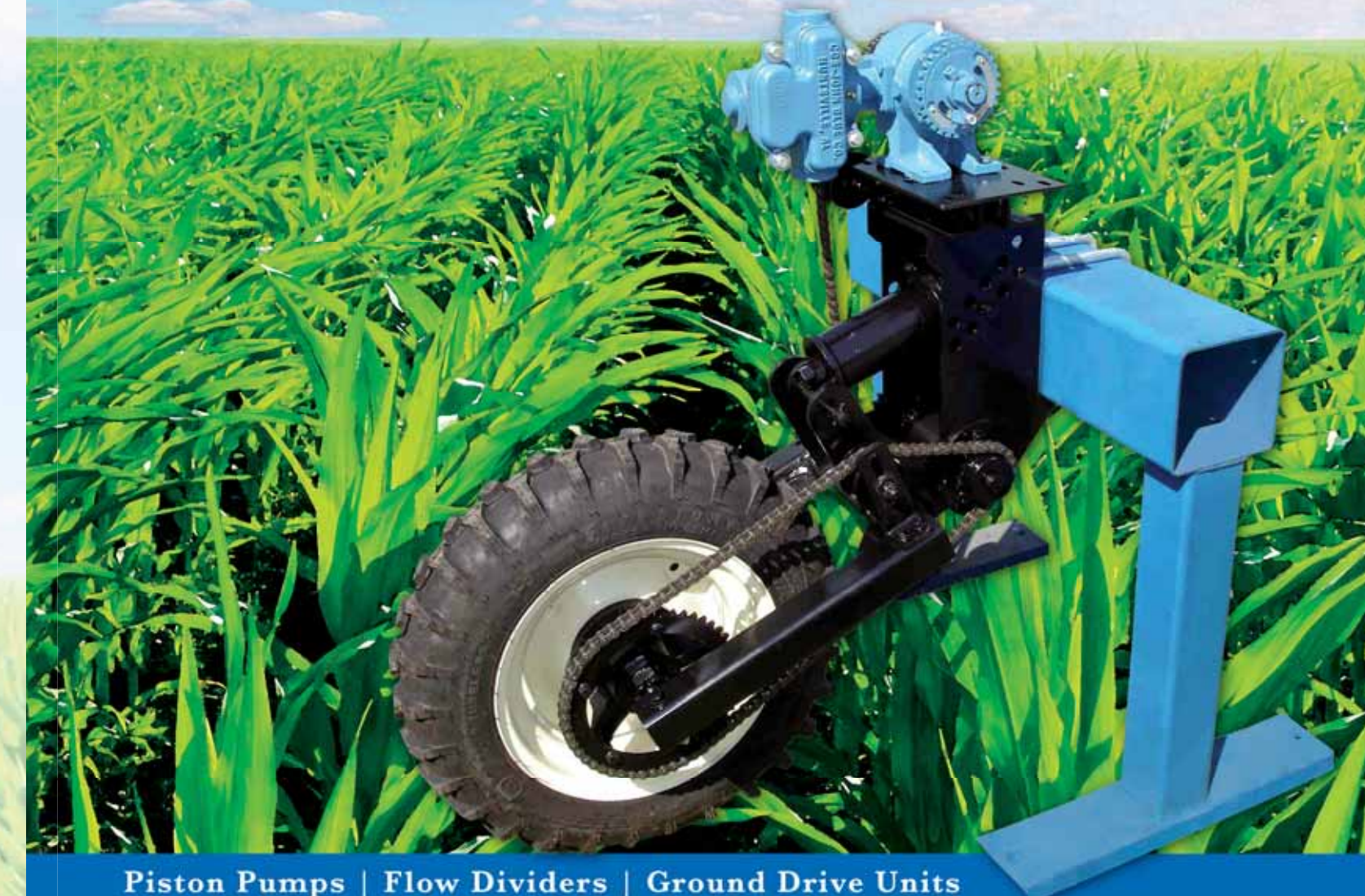

Piston Pumps | Flow Dividers | Ground Drive Units

Fertilizer Applications Must Be:

It All Starts with the Best Pump

Select the Best CDS-John Blue Piston Pump to Fit Your Needs

Reliable Precision Placement For All Of Your Fertilizer Needs

Accurate

Your rates need to be correct

Repeatable

Your rate today needs to be the same today and tomorrow

Flexible

When rates change the pump is easy to adjust

Reliable

It Works Today, Tomorrow and Next Year

CDS-John Blue Company has the Complete System for Low Volume or High Volume Planters and Applicators

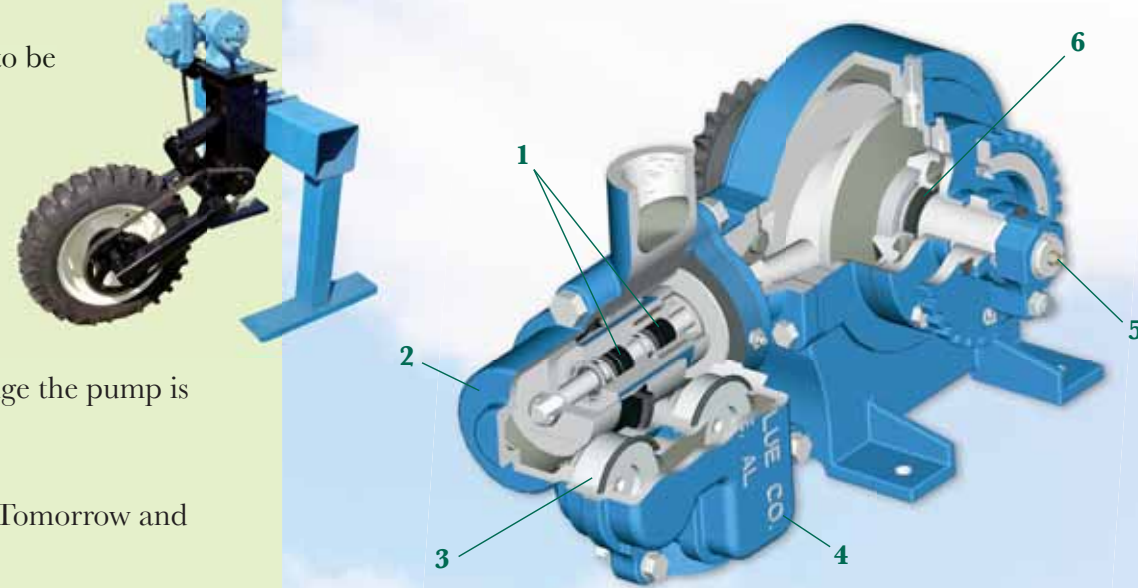

- 1. Universal piston rod seals** work in unison to offer multiple stage piston protection between the wet end and crank case.
- 2. Outboard cylinder plunger packing** can be inspected or replaced in the field without removing the hoses.
- 3. Check Valves** are designed for positive seal, easy priming and long life.
- 4. Single Valve Cap** makes easy access to check valves without removing the hoses. Simple to service in the field.
- 5. Common or Independent Manifolds** are available on the double pumps. Independent manifolds allow for dual flow divider usage or half width application.
- 6. Main Shaft Seals** incorporate a dual wiper that is enclosed in a grease cavity to flush out contamination. This helps to extend the life of the pump.



LM-1250 Series		MODELS AVAILABLE:	
Single Piston - Double Acting	Rated Speed - 550 RPM	LM-1250	Rope Control Clutch
Stroke - Variable	Inlet - 1" FPT	LM-1255	Without Clutch
Rated Flow - 12.5 GPM	Outlet - 1" FPT		
Rated Pressure - 120 PSI	Clutch - No Clutch		

Rows	Swath in Inches		LM-1255 Application Range in GPA			
			30 Inch Spacing		36 Inch Spacing	
	30	36	Min	Max	Min	Max
4	120	144	4.5	123.8	3.8	103.1
8	240	288	2.3	61.9	1.9	51.6
12	360	432	1.5	41.3	1.3	34.4
16	480	576	1.1	30.9	0.9	25.8
24	720	864	0.8	20.6	0.6	17.2
36	1080	1296	0.5	13.8	0.4	11.5



NGP-6050 Series *		MODELS AVAILABLE:	
Single Piston - Double Acting	Rated Speed - 450 RPM	NGP-6050	Rope Control Clutch
Stroke - Variable	Inlet - 1-1/2" FPT	NGP-6055	Without Clutch
Rated Flow - 21.0 GPM	Outlet - 1-1/2" FPT	NGP-6058	Electric Control Clutch
Rated Pressure - 120 PSI	Clutch - Various Options	NGP-6059	Hydraulic Control Clutch

*Equivalent LM-2450 series

Rows	Swath in Inches		NGP-6055 Application Range in GPA			
			30 Inch Spacing		36 Inch Spacing	
	30	36	Min	Max	Min	Max
4	120	144	9.2	207.9	7.7	173.3
8	240	288	4.6	104.0	3.9	86.6
12	360	432	3.1	69.3	2.6	57.8
16	480	576	2.3	52.0	1.9	43.3
24	720	864	1.5	34.7	1.3	28.9
36	1080	1296	1.0	23.1	0.9	19.3



NGP-7050 Series *		MODELS AVAILABLE:	
Single Piston - Double Acting	Rated Speed - 450 RPM	NGP-7050	Rope Control Clutch
Stroke - Variable	Inlet - 1-1/2" FPT	NGP-7055	Without Clutch
Rated Flow - 34.2 GPM	Outlet - 1-1/2" FPT	NGP-7058	Electric Control Clutch
Rated Pressure - 120 PSI	Clutch - Various Options	NGP-7059	Hydraulic Control Clutch

*Equivalent LM-4450 series

Rows	Swath in Inches		NGP-7055 Application Range in GPA			
			30 Inch Spacing		36 Inch Spacing	
	30	36	Min	Max	Min	Max
4	120	144	15.0	338.6	12.5	282.2
8	240	288	7.5	169.3	6.3	141.1
12	360	432	5.0	112.9	4.2	94.1
16	480	576	3.8	84.6	3.1	70.5
24	720	864	2.5	56.4	2.1	47.0
36	1080	1296	1.7	37.6	1.4	31.4

NGP-8050 Series		MODELS AVAILABLE:	
Double Piston - Double Acting	Rated Speed - 450 RPM	NGP-8050	Rope Control Clutch
Stroke - Variable	Inlet - 1-1/2" FPT	NGP-8055	Without Clutch
Rated Flow - 42 GPM	Outlet - 1-1/2" FPT	NGP-8058	Electric Control Clutch
Rated Pressure - 120 PSI	Clutch - Various Options	NGP-8059	Hydraulic Control Clutch

Rows	Swath in Inches		NGP-8055 Application Range in GPA			
			30 Inch Spacing		36 Inch Spacing	
	30	36	Min	Max	Min	Max
4	120	144	18.5	415.8	15.4	346.5
8	240	288	9.2	207.9	7.7	173.3
12	360	432	6.2	138.6	5.1	115.5
16	480	576	4.6	104.0	3.9	86.6
24	720	864	3.1	69.3	2.6	57.8
36	1080	1296	2.1	46.2	1.7	38.5



Photo of DR Pump - Pump with independent dual inlet and outlet manifolds.

NGP-9050 Series *		MODELS AVAILABLE:	
Double Piston - Double Acting	Rated Speed - 450 RPM	NGP-9050	Rope Control Clutch
Stroke - Variable	Inlet - 1-1/2" FPT	NGP-9055	Without Clutch
Rated Flow - 68.4 GPM	Outlet - 1-1/2" FPT	NGP-9058	Electric Control Clutch
Rated Pressure - 120 PSI	Clutch - Various Options	NGP-9059	Hydraulic Control Clutch

*Equivalent LM-4950 series Rated Flow based on 12 lbs. per gallon fertilizer 316 SS available with wet end casting

Rows	Swath in Inches		NGP-9055 Application Range in GPA			
			30 Inch Spacing		36 Inch Spacing	
	30	36	Min	Max	Min	Max
4	120	144	30.1	677.2	25.1	564.3
8	240	288	15.0	338.6	12.5	282.2
12	360	432	10.0	225.7	8.4	188.1
16	480	576	7.5	169.3	6.3	141.1
24	720	864	5.0	112.9	4.2	94.1
36	1080	1296	3.3	75.2	2.8	62.7



Buy The Complete System Or Buy Individual Components:

Piston Pumps, Mountings, DRV (Ground Drives) and Flow Dividers.

How to Select Your Complete CDS-John Blue Fertilizer Package:

- How many rows do you have?
- What is your swath width (row spacing distance multiplied by number of rows)?
- What application rate do you want to achieve?
- Now simply select the CDS-John Blue Piston Pump that best fits your needs (see chart on right under each pump series description).

Now select your CDS-John Blue Flow Divider:

- How many outlets do you need?
- For 12 outlets or less select the FD-1200.
- For 20 outlets or less select the FD-2000.

- Multiple flow dividers can be used with DR series pumps.
- Check valves are available for any application, see chart on Flow Divider page.

Finally, selecting your CDS-John Blue DRV (Ground Drive):

- DRV-3300 Complete Ground Drive that automatically adjust for your terrain.
- DRV-3200 Universal Mount that uses the existing shaft from your planter.
- DRV-3100 gage wheel only.
- DRV-3000 is ideal for fixed height.

Note: Standard Piston Pumps are manufactured with Viton Piston Packings and Buna o-rings and rod packings.

*** -DR pumps may use 2 single piston stainless conversion kits

Additional Model Options [-suffix]:

- DR** denotes independent dual inlet & outlet
- K denotes pump less sprocket
- R denotes RC40 chain 18 tooth sprocket
- S denotes 316SS wet-end castings
- U denotes Viton wet-end o-rings and rod packing

** -DR only available on double piston NGP-8050 & NGP-9050

Additional Kit Modules (modifies existing pumps):

- 115670 Manual Clutch Add On - NGP Universal
- 115671 Hydraulic Clutch Add On - NGP Universal
- 115672 Electric Clutch Add On - NGP Universal
- 115673 Stainless Wet-End Conversion - NGP-6050 Series
- 115674 Stainless Wet-End Conversion - NGP-7050 Series
- 115675 Stainless Wet-End Conversion - NGP-8050 Series***
- 115676 Stainless Wet-End Conversion - NGP-9050 Series***